

# TPS/TPSS Series Pallet Scales



## Features :

- Capacity to 2t
- Instant weight readings are available as soon as the forks are raised
- Function include change weighing, unit, net/gross shift,
- Stainless Steel high quality 304 grade
- Ip67 waterproof (Truck base without indicator)
- IP66 waterproof rate (indicator)
- Rugged construction for long life
- Rechargeable battery provide up to 30 hours of continuous use (without backlight)

## Dimension(mm)

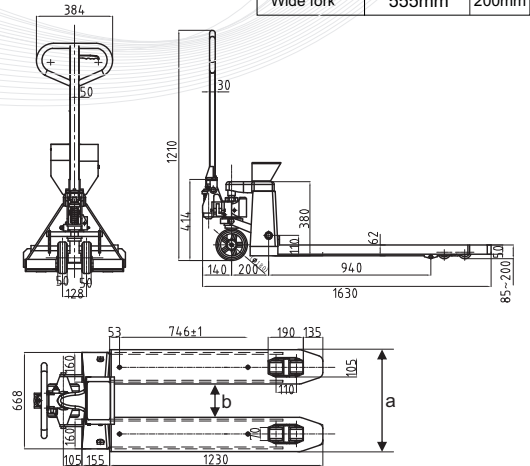

## Specification:

Model	
Display	26mm LCD display, attached white color LED display
Capacity	2t
Readability	1kg
Keyboard	11 keys mechanical
Housing	Stainless Steel 304
Max. Divisions	2,000d
ADC	Sigma delta
ADC update	1/10 second
Operate Temp	-10°C~+40°C
Power	Rechargeable battery (6V/10Ah), AC adapter (12V/500mA),
Gross weight	160kg